

English

Agricultural telehandlers

MLT NewAg

MLT 635-130 PS+ (S2)

MACHINEBOOK



Capacities		Metric
Max. capacity	Q	3500 kg
Max. lifting height	h3	6.13 m
Maximum outreach		3.26 m
Reach at max. height		0.60 m
Breakout force with bucket		5900 daN
Weight and dimensions		
Unladen weight (with forks)		7490 kg
Ground clearance	m4	0.41 m
Wheelbase	y	2.60 m
Overall length to carriage (with hitch)	l11	4.71 m
Front overhang		1.16 m
Overall width	b1	2.39 m
Overall cab width	b4	0.95 m
Overall height	h17	2.38 m
Tilt-down angle	a5	133 °
Tilt-up angle	a4	14 °
External turning radius (over tyres)	Wa1	3.77 m
Standard tires		Alliance - A580 - 460/70 R24 159A8
Drive wheels (front / rear)		2 / 2
Steering wheels (front / rear)		2 / 2
Performances		
Lifting		6.40 s
Lowering		5.30 s
Extension		5 s
Retraction		4.30 s
Crowd		3.70 s
Dump		3 s
Engine		
Engine brand		Deutz
Engine norm		Stage V
Engine model		TCD 3.6 L4
Number of cylinders - Capacity of cylinders		4 - 3621 cm ³
Engine power (Hp / kW)		129 Hp / 95 kW
Max. torque / Engine rotation		500 Nm @1600 rpm
Drawbar pull (Laden)		7870 daN
Reversible fan		Standard
Engine cooling system		4 radiators (water + intercooler + hydraulic oil + transmission oil)
HVO validated (according to EN 15940 standard)		Yes
Transmission		
Transmission type		Torque converter
Gearbox		Powershift
Number of gears (forward / reverse)		6 / 3
Max. travel speed (may vary according to applicable regulations)		40 km/h
Differential lock		Limited slip differential on front axle
Parking brake		Automatic negative parking brake
Service brake		Oil-immersed multi-discs braking on front & rear axles
Hydraulics		
Hydraulic pump type		Variable displacement pump
Hydraulic flow - Pressure		150 l/min - 270 bar
Flow sharing distributor		Standard
Tank capacities		
Hydraulic tank capacity		135 l
Fuel tank		120 l
Diesel Exhaust fluid (AdBlue® type)		10 l
Noise and vibration		
Noise at driving position (LpA) tested following NF EN 12053 norm		72 dB
Vibration on hands/arms		< 2.50 m/s ²
Miscellaneous		
Tractor homologation		Tractor homologation
Cab certification		Cabin ROPS - FOPS level 2
Controls		JSM

Optional tires tab

	Overall height	Overall width
ALLIANCE - A585 - 460/70 R24 159A8	2.37 m	2.40 m
NOKIAN - TRI STEEL - 460/65 R24 156A8	2.36 m	2.40 m
MICHELIN - BIBLOAD - 460/70 R24 159A8	2.37 m	2.40 m
MICHELIN - XHA - 15.5 R25 158A2	2.37 m	2.40 m
MICHELIN - XMCL - 460/70 R24 159A8	2.37 m	2.40 m
TRELLEBORG - TH400 - 460/70 R24 159A8	2.37 m	2.40 m
TRELLEBORG - TH500 - 460/70 R24 159A8	2.37 m	2.40 m
VREDESTEIN - ENDURION - 460/70 R24 159A8	2.38 m	2.41 m

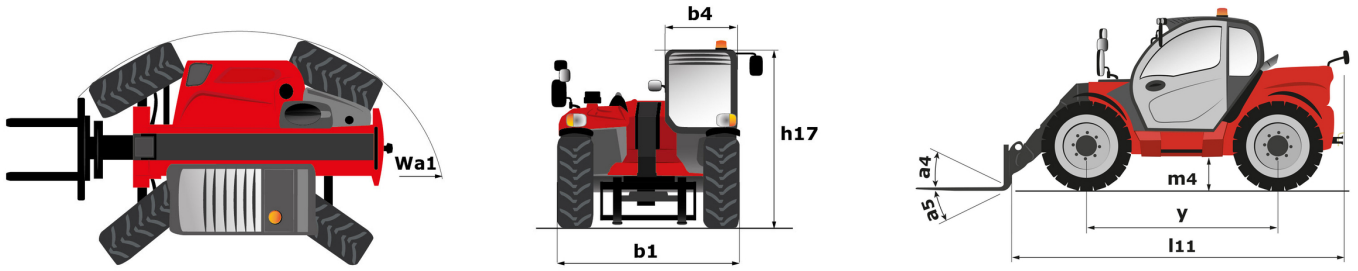

MLT 635-130 PS+ (S2) - LOAD CHART

Machine on tires with forks Metric

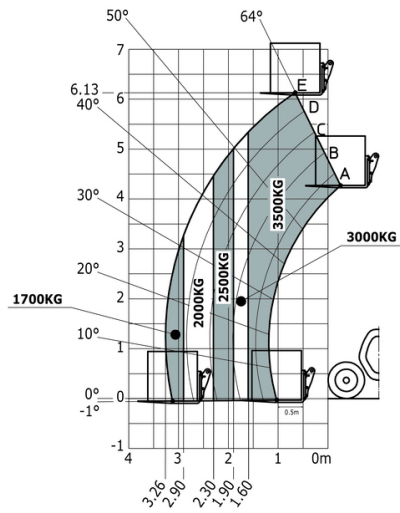

BUCKETS

Agricultural Bucket



Agricultural Bucket - CBA 1500 / 2450

Distance to center of gravity	Capacity	Heaped capacity	Struck capacity	Overall weight	Overall height
542 mm	1529 kg	1529 l	1101 l	500 kg	997 mm
Overall length	Width	Reference number	Reference number with bolted wearplate (WP)		
1170 mm	2450 mm	570547	570548		

Mandatory machine equipment: ✕



Agricultural Bucket - CBA 2000 / 2450

Distance to center of gravity	Capacity	Heaped capacity	Struck capacity	Overall weight	Overall height
485 mm	2010 kg	2010 l	1484 l	557 kg	1150 mm
Overall length	Width	Reference number	Reference number with bolted wearplate (WP)		
1204 mm	2450 mm	570551	570552		

Mandatory machine equipment: ✕

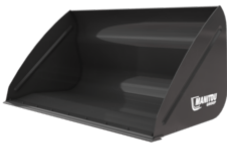

Agricultural Bucket - CBA 2500L / 2450

Distance to center of gravity	Capacity	Heaped capacity	Struck capacity	Overall weight	Overall height
537 mm	2526 kg	2526 l	1916 l	675 kg	1250 mm
Overall length	Width	Reference number	Reference number with bolted wearplate (WP)		
1497 mm	2450 mm	570553	570554		

Mandatory machine equipment: ✕

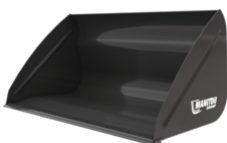

Agricultural Bucket - CBA 3000 / 2500

Distance to center of gravity	Capacity	Heaped capacity	Struck capacity	Overall weight	Overall height
583 mm	3023 kg	3023 l	2342 l	753 kg	1314 mm
Overall length	Width	Reference number	Reference number with bolted wearplate (WP)		
1733 mm	2500 mm	570555	500701		

Mandatory machine equipment: ✕

BUCKETS

Agricultural Multifunction Grab Bucket - FO



Agricultural Multifunction Grab Bucket - FO - BG 2450 / 1400 FO

Distance to center of gravity	Capacity	Heaped capacity	Struck capacity	Overall weight	Overall length
407 mm	1426 kg	1426 l	868 l	803 kg	1256 mm
Width	Closed grapple height	Opened grapple height	Reference number		
2450 mm	1033 mm	1675 mm	52647333		

Mandatory machine equipment: 



Agricultural Multifunction Grab Bucket - FO - BG 2450 / 1700 FO

Capacity	Heaped capacity	Struck capacity	Overall weight	Overall length	Width
1695 kg	1695 l	1150 l	870 kg	1367 mm	2450 mm
Closed grapple height	Opened grapple height	Reference number			
1124 mm	1886 mm	52549810			

Mandatory machine equipment: 

BUCKETS

Agricultural Multifunction Grab Bucket - WE



Agricultural Multifunction Grab Bucket - WE - BG 2450 / 1400 WE

Distance to center of gravity	Capacity	Heaped capacity	Struck capacity	Overall weight	Overall length
418 mm	1426 kg	1426 l	868 l	813 kg	1280 mm
Width	Closed grapple height	Opened grapple height	Reference number		
2450 mm	1033 mm	1776 mm	52647332		

Mandatory machine equipment: 



Agricultural Multifunction Grab Bucket - WE - BG 2450 / 1700 WE

Distance to center of gravity	Capacity	Heaped capacity	Struck capacity	Overall weight	Overall length
1021 mm	1695 kg	1695 l	1150 l	895 kg	1377 mm
Width	Closed grapple height	Opened grapple height	Reference number		
2450 mm	1124 mm	1979 mm	52549720		

Mandatory machine equipment: 

BUCKETS

Big Bag Filling Bucket



Big Bag Filling Bucket - BBF 1200 / 600

Heaped capacity	Overall weight	Overall height	Overall length	Width	Reference number
600 l	455 kg	685 mm	1549 mm	1200 mm	52676645

Mandatory machine equipment: 



Big Bag Filling Bucket - BBF 1400 / 1100

Heaped capacity	Overall weight	Overall height	Overall length	Width	Reference number
1120 l	610 kg	923 mm	1723 mm	1400 mm	52614700

Mandatory machine equipment: 



Big Bag Filling Bucket - BBF 1650 / 1750

Heaped capacity	Overall weight	Overall height	Overall length	Width	Reference number
1750 l	750 kg	1158 mm	1896 mm	1650 mm	52634800

Mandatory machine equipment: 

BUCKETS

Bucket 4 in 1



Bucket 4 in 1 - CB4x1 900L / 2450

Distance to center of gravity	Capacity	Heaped capacity	Struck capacity	Overall weight	Overall height
380 mm	1888 kg	899 l	672 l	714 kg	890 mm
Overall length	Width	Reference number			
1110 mm	2450 mm	751465			

Mandatory machine equipment: 

BUCKETS

Concrete Mixing Bucket



Concrete Mixing Bucket - BMC 500

Capacity	Overall weight	Overall height	Width	Depth	Reference number
500 kg	770 kg	1050 mm	1950 mm	1050 mm	52728343

Mandatory machine equipment: +

BUCKETS

Construction Bucket



Construction Bucket - CBC 900L / 2450

Distance to center of gravity	Capacity	Heaped capacity	Struck capacity	Overall weight	Overall height
365 mm	1875 kg	893 l	728 l	391 kg	810 mm
Overall length	Width	Reference number			
1026 mm	2450 mm	654470			

Mandatory machine equipment:

BUCKETS

Environment Bucket



Environment Bucket - BEN 2500 / 3000 WP

Distance to center of gravity	Capacity	Heaped capacity	Struck capacity	Overall weight	Overall height
679 mm	2900 kg	2900 l	2300 l	1030 kg	1323 mm
Overall length	Width	Reference number			
1746 mm	2500 mm	52736126			

Mandatory machine equipment:



Environment Bucket - CBA 2450 / 2200 EN

Distance to center of gravity	Capacity	Heaped capacity	Struck capacity	Overall weight	Overall height
642 mm	2224 kg	2224 l	1371 l	911 kg	1223 mm
Overall length	Width	Reference number			
1487 mm	2450 mm	52000524			

Mandatory machine equipment:

BUCKETS

Environment Grab Bucket



Environment Grab Bucket - CBG 2450 / 1600 EN

Capacity	Heaped capacity	Struck capacity	Overall weight	Overall length	Width
1568 kg	1568 l	1262 l	926 kg	1259 mm	2450 mm
Opened grapple height	Reference number				
1868 mm	52000563				

Mandatory machine equipment: 



Environment Grab Bucket - CBG 2450 / 1600 EN WB

Distance to center of gravity	Capacity	Heaped capacity	Struck capacity	Overall weight	Overall length
609 mm	1568 kg	1568 l	1262 l	947 kg	1259 mm
Width	Opened grapple height	Reference number			
2450 mm	1868 mm	52000766			

Mandatory machine equipment: 

BUCKETS

General Purpose Bucket



General Purpose Bucket - CBR 1000 / 2450

Capacity	Heaped capacity	Struck capacity	Overall weight	Overall height	Overall length
2079 kg	990 l	804 l	381 kg	775 mm	815 mm
Width	Reference number	Reference number with bolted wearplate (WP)			
2450 mm	654716	52000370			

Mandatory machine equipment: 

BUCKETS

General Purpose Bucket Essential



General Purpose Bucket Essential - BGP 2300 / 900 Essential

Distance to center of gravity	Capacity	Heaped capacity	Struck capacity	Overall weight	Overall height
429 mm	1955 kg	931 l	718 l	379 kg	786 mm
Overall length	Width	Depth	Reference number		
975 mm	2300 mm	817 mm	52690756		

Mandatory machine equipment: 



General Purpose Bucket Essential - BGP 2450 / 1000 Essential

Distance to center of gravity	Capacity	Heaped capacity	Struck capacity	Overall weight	Overall height
434 mm	2089 kg	995 l	766 l	397 kg	786 mm
Overall length	Width	Depth	Reference number		
925 mm	2450 mm	817 mm	52658055		

Mandatory machine equipment: ✕

BUCKETS

Shear buckets

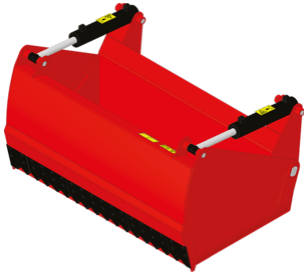

Shear buckets - SHB 2200 / 1650

Distance to center of gravity	Capacity	Heaped capacity	Overall weight	Overall height	Overall length
522 mm	1650 kg	1650 l	892 kg	1010 mm	1295 mm
Width	Opened grapple height	Depth	Reference number		
2254 mm	1475 mm	850 mm	52000386		

Mandatory machine equipment: 



BUCKETS

Silage Facing Bucket



Silage Facing Bucket - CRS 2550 / 2000

Capacity	Heaped capacity	Overall weight	Width	Reference number
2000 kg	2000 l	955 kg	2550 mm	52612540

Mandatory machine equipment:  + 

BUCKETS

Sugar Beet Bucket

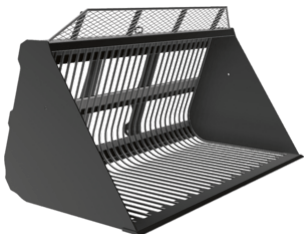

Sugar Beet Bucket - BSB 2450 / 2500

Distance to center of gravity	Capacity	Heaped capacity	Overall weight	Overall height	Overall length
502 mm	1390 kg	2500 l	520 kg	1380 mm	1375 mm
Width	Depth	Reference number			
2450 mm	1280 mm	757953			

Mandatory machine equipment: ✕

CLAMPS

Bale clamp classic



Bale clamp classic - CLBR 2x3

Capacity	Overall weight	Overall height	Overall length	Forks length	Width
1200 kg	235 kg	1382 mm	1082 mm	335 mm	1090 mm
Arm length	Reference number				
700 mm	52001013				

Mandatory machine equipment:



Bale clamp classic - PBG 2x4

Capacity	Overall weight	Overall height	Overall length	Forks length	Width
1800 kg	235 kg	1381 mm	1031 mm	335 mm	1090 mm
Arm length	Reference number				
600 mm	757612				

Mandatory machine equipment:

CLAMPS

Bale clamp high intensive



Bale clamp high intensive - CLBR 2x6

Capacity	Overall weight	Overall height	Overall length	Forks length	Width
2000 kg	434 kg	2256 mm	1276 mm	335 mm	1002 mm
Arm length	Reference number				
700 mm	757666				

Mandatory machine equipment:

CLAMPS

Bale Clamp Intensive



Bale Clamp Intensive - P2BG 2x4

Capacity	Overall weight	Overall height	Overall length	Width	Arm length
1800 kg	283 kg	1776 mm	1047 mm	1090 mm	600 mm
Reference number					
790518					

Mandatory machine equipment:

CLAMPS

Bale Clamp Super Compact



Bale Clamp Super Compact - PBG 2x2

Capacity	Overall weight	Overall height	Overall length	Forks length	Width
800 kg	156 kg	869 mm	922 mm	335 mm	1090 mm
Arm length	Reference number				
500 mm	757639				

Mandatory machine equipment: 

CLAMPS

Mixed Bale Clamp



Mixed Bale Clamp - MBC 2x3

Capacity	Overall weight	Overall height	Overall length	Forks spread	Width
800 kg	290 kg	1084 mm	1454 mm	375 mm	1196 mm
Reference number					
790506					

Mandatory machine equipment: 

CLAMPS

Square wrapped bale clamp



Square wrapped bale clamp - CLBSW 2000 / 1000

Capacity	Overall weight	Overall height	Overall length	Width	Arm length
1000 kg	483 kg	679 mm	1849 mm	1525 mm	1000 mm
Reference number					
52000812					

Mandatory machine equipment: 

CLAMPS

Wood Clamp



Wood Clamp - CLHW 1200/3

Capacity	Overall weight	Overall height	Overall length	Width	Closed grapple height
3000 kg	461 kg	1185 mm	1091 mm	1248 mm	1185 mm
Opened grapple height	Minimum diameter / Maximum diameter	Reference number			
1429 mm	460 mm / 900 mm	52797759			

Mandatory machine equipment: 

CLAMPS

Wrapped Bale Clamp



Wrapped Bale Clamp - CLBW 800

Capacity	Overall weight	Overall height	Overall length	Width	Reference number
800 kg	227 kg	810 mm	1386 mm	1587 mm	52000813

Mandatory machine equipment: 



Wrapped Bale Clamp - CLBW 1500

Capacity	Overall weight	Overall height	Overall length	Width	Reference number
1500 kg	251 kg	810 mm	1490 mm	1587 mm	52001012

Mandatory machine equipment: 

ON FORK HANDLING SOLUTIONS

Carriage Floating Load Backrest And Forks (MT - MLT)



Carriage Floating Load Backrest And Forks (MT - MLT) - CAF 1000 / 4.1 LB

Distance to center of gravity	Capacity	Overall weight	Overall height	Overall length	Width
275 mm	4100 kg	306 kg	1036 mm	1514 mm	1160 mm

Reference number
52722290

Mandatory machine equipment: ✕

ON FORK HANDLING SOLUTIONS

Tilting Forks Carriage



Tilting Forks Carriage - PFB 35N 1260

Capacity	Overall weight	Width	Reference number
3500 kg	93 kg	1302 mm	653744

Mandatory machine equipment: ✕



Tilting Forks Carriage - PFB 35N 1470

Capacity	Overall weight	Width	Reference number
3500 kg	117 kg	1512 mm	653745

Mandatory machine equipment: ✕



Tilting Forks Carriage - PFB 35N 1580

Capacity	Overall weight	Width	Reference number
3500 kg	122 kg	1622 mm	653746

Mandatory machine equipment: ✕

ON FORK HANDLING SOLUTIONS

Tilting Forks Carriage With Load Backrest (MLT - MT)



Tilting Forks Carriage With Load Backrest (MLT - MT) - PFB 35N 1260 LB

Capacity	Overall weight	Overall height	Width
3500 kg	130 kg	1185 mm	1284 mm

Mandatory machine equipment: ✕



Tilting Forks Carriage With Load Backrest (MLT - MT) - PFB 35N 1470 LB

Capacity	Overall weight	Overall height	Width
3500 kg	158 kg	1185 mm	1494 mm

Mandatory machine equipment: ✕

ON FORK HANDLING SOLUTIONS

Tilting Forks Carriage With Side Shift (MLT - MT)



Tilting Forks Carriage With Side Shift (MLT - MT) - PFB 35N 1260 SS

Capacity	Overall weight	Overall height	Width
3500 kg	175 kg	658 mm	1260 mm

Mandatory machine equipment:

FORKS & GRABS

Fork Bale Cotton



Fork Bale Cotton - FBC 5 / 5000

Distance to center of gravity	Capacity	Overall weight	Overall height	Overall length	Width
535 mm	5000 kg	388 kg	1072 mm	2477 mm	1516 mm

Reference number
52775361

Mandatory machine equipment:

FORKS & GRABS

High Capacity Silage & Manure Grab



High Capacity Silage & Manure Grab - FMG 2450 / 2000

Capacity	Heaped capacity	Overall weight	Overall length	Forks length	Width
1400 kg	2000 l	686 kg	1381 mm	990 mm	2435 mm

Closed grapple height
1201 mm

Reference number
790534

Mandatory machine equipment:

FORKS & GRABS

Manure Fork With Grapple



Manure Fork With Grapple - FFGR 2100

Capacity	Heaped capacity	Overall weight	Overall length	Forks length	Forks spread
1700 kg	1100 l	492 kg	1322 mm	810 mm	225 mm

Width
2100 mm

Closed grapple height
1138 mm

Opened grapple height
1636 mm

Reference number
751403

Mandatory machine equipment:



Manure Fork With Grapple - FFGR 2400

Capacity	Heaped capacity	Overall weight	Overall length	Forks length	Forks spread
1700 kg	1300 l	528 kg	1325 mm	810 mm	225 mm
Width	Closed grapple height	Opened grapple height	Reference number		
2400 mm	1138 mm	1615 mm	751405		

Mandatory machine equipment: 

FORKS & GRABS

Shear Grab



Shear Grab - SHG 2200 / 1650

Capacity	Heaped capacity	Overall weight	Overall length	Width	Closed grapple height
1447 kg	1608 l	835 kg	1295 mm	2254 mm	1010 mm
Opened grapple height	Depth	Reference number			
1475 mm	850 mm	52000382			

Mandatory machine equipment: 

FORKS & GRABS

Square Bale Forks



Square Bale Forks - FB 1900 / 1700

Capacity	Overall weight	Overall height	Overall length	Forks length	Forks spread
1700 kg	215 kg	2236 mm	1341 mm	1010 mm	600 mm
Width	Reference number				
1878 mm	790699				

Mandatory machine equipment: 

JIBS

Big Bag Handler



Big Bag Handler - HBB 1500 / 2400

Distance to center of gravity	Capacity	Overall weight	Overall height	Overall length	Forks spread
388 mm	2400 kg	186 kg	1322 mm	1643 mm	750 mm
Width	Reference number	Reference number E-RECO	Skid Steer Carriage reference	4 point Carriage	Euro Carriage
1356 mm	52781808	931627	52578030	52742058	52742059

Mandatory machine equipment: 

JIBS

Frame Mounted Hook



Frame Mounted Hook - PC 50

Distance to center of gravity	Capacity	Overall weight	Maximum outreach	Overall height	Overall length
166 mm	5000 kg	115 kg	470 mm	500 mm	606 mm
Width	Reference number	Reference number E-RECO			
815 mm	708544	921335			

Mandatory machine equipment: ✕

SWEEPER & CLEANER

High pressure cleaner



High pressure cleaner - VHPC 600

Overall weight	Overall height	Overall length	Width	Cable length	Reference number
240 kg	1500 mm	1200 mm	1450 mm	40000 mm	790335

Mandatory machine equipment: +

SWEEPER & CLEANER

Pickup Sweeper



Pickup Sweeper - BRB 2200

Distance to center of gravity	Overall weight	Overall height	Overall length	Width	Reference number
1050 mm	925 kg	1068 mm	2370 mm	2600 mm	790315

Mandatory machine equipment: +

SWEEPER & CLEANER

Push broom

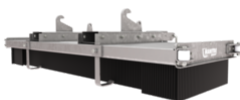

Push broom - SCP 2500

Overall weight	Overall height	Overall length	Width	Reference number
184 kg	494 mm	1030 mm	2490 mm	52804221

Mandatory machine equipment: ✕

SWEEPER & CLEANER

Sweeper 2 in 1



Sweeper 2 in 1 - SCC 2600

Overall weight	Overall height	Overall length	Width	Reference number
755 kg	950 mm	2140 mm	2820 mm	52000515

Mandatory machine equipment:



Sweeper 2 in 1 - SCC 2600 +

Overall weight	Overall height	Overall length	Width	Reference number	Reference number E-RECO
730 kg	950 mm	2170 mm	2820 mm	52000517	52000517

Mandatory machine equipment:



Sweeper 2 in 1 - SCC 2600 HWA +

Overall weight	Overall height	Overall length	Width	Reference number
800 kg	1550 mm	2170 mm	2820 mm	52000519

Mandatory machine equipment: +

LEVELLING SOLUTIONS

Grain Pusher



Grain Pusher - BLGP 2320 / 3900

Overall weight	Overall height	Overall length	Width	Reference number
439 kg	946 mm	3942 mm	2320 mm	52812920

Mandatory machine equipment:

MISCELLANEOUS ATTACHMENTS

Material Basket



Material Basket - MB 2000 / 1000

Distance to center of gravity	Capacity	Overall weight	Overall height	Overall length	Width
694 mm	1000 kg	400 kg	1215 mm	1632 mm	2056 mm
Depth	Reference number				
1120 mm	52596600				

Mandatory machine equipment: X

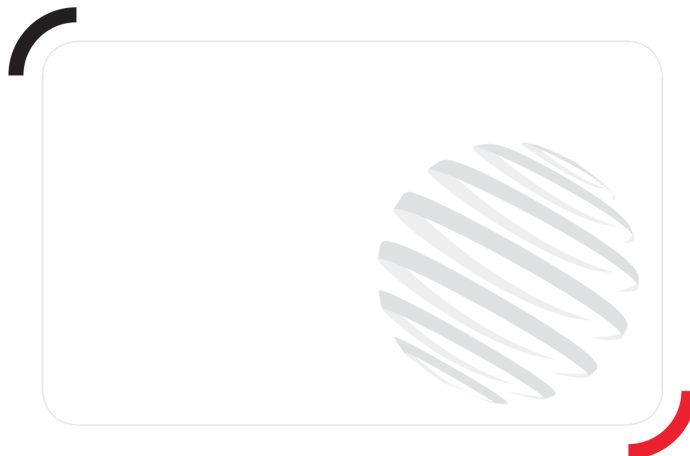

Head Office

B.P. 249 - 430 rue de l'Aubinière
44150 Ancenis Cedex - France

Tel: +33 (0)2 40 09 10 11 - Fax: +33 (0)2 40 09 10 97

www.manitou.com



This publication provides a description of the configuration versions and options for Manitou products, which may differ for equipment. The equipment presented in this brochure may be part of a series, as an option, or it may not be available, depending on the versions. Manitou reserves the right, at any time and without notice, to amend the specifications described and represented. The specifications provided do not bind the manufacturer. For more details, please contact your Manitou agent. This is not a contractually binding document. The presentation of the products is not contractually binding. List of specifications non-exhaustive.

The logos as well as the visual identity of the company are owned by Manitou and cannot be used without authorisation. All rights reserved. The photos and diagrams contained in this brochure are only provided for consultation and information purposes.

MANITOU BF SA - Limited company with board of directors - Share capital: 39,668,399 euros - 857 802 508 RCS Nantes