

# X7

650-660-670-690 P6-DRIVE / 670 VT DRIVE



**McCORMICK**





# McCORMICK X7, ON THE CUTTING EDGE; BUILT FOR AGRICULTURE

Each McCormick tractor reflects the passion and dedication of those involved in designing, testing and producing this incredible line-up of tractors. The new X7 tractors offer the ultimate in style, technology, operator comfort and productivity.

Four models in the tractor range are all powered by new BETAPOWER six-cylinder turbocharged diesel engines with multi-valve technology and common rail fuel injection. These engines meet Tier 4 emissions regulations using advanced SCR, an exhaust gas after-treatment technology that reduces harmful emissions without compromising engine performance.

The X7 models are equipped with 6.7 liter, 6-cylinder engines that sit in a heavy cast steel frame, which helps reduce noise and vibration levels within the cab.

The X7 range comes with a choice of two transmissions: P6-Drive and VT-Drive. The new P6-Drive models offer 54 speeds with 6 powershifts. All speed changes are fully automated using convenient push button controls.

The VT-Drive transmission is a continuously variable transmission (CVT) that provides infinite speeds, from zero to maximum travel speed, with smooth acceleration and seamless performance.

Both transmissions have a power shuttle lever on the left side of the steering column, while speed controls reside in the right-hand multi function controller.

## HIGHLIGHTS

MODEL	RATED HP	MAX HP	MAX HP WITH POWER PLUS
<b>X7.650</b>	146	151	165
<b>X7.660</b>	160	165	180
<b>X7.670</b>	175	180	192
<b>X7.690</b>	199	205	222

- › Manufactured, Designed, and Engineered by McCormick.
- › 6.7 liter BETAPOWER diesel engine
- › Spacious 4 post cab design with flat foot deck, easy access, & hideaway instructor's seat
- › Multi-Function Control armrest with integrated controls (premium & CVT models) for effortless operation
- › Instrument Panel tilting with steering column and available color touch screen monitor
- › Automatic climate control for increased operator comfort
- › Turbocharged and intercooled with electronic engine management for power and fuel efficiency
- › Efficiency features for increased ease of maintenance
- › Electro-hydraulic range shifting for ease of operation
- › Auto Power Shift system with automated speed changes for reduced workload
- › 32 mph (50kph) transport capability
- › Electronic 4wd clutch automatically engages for 4-wheel braking and added safety
- › Fully locking front and rear differentials
- › Closed Center PFC hydraulic system for on demand hydraulic flow without power waste
- › 4 speed PTO standard equipment





**HOOD DESIGN**

FAMILY STYLE

**CAB**

STANDARD & PREMIUM  
OPTIONS

**ENGINE**

BETAPOWER, 6.7 L

**REAR HITCH**

20,500 LB LIFT  
(PREMIUM & CVT)

**CHASSIS**

CAST STEEL  
FRONT FRAME

**TRANSMISSION**

POWER SHIFT &  
VT-DRIVE (CVT)

**REAR PTO**

540/540E/1000/1000E

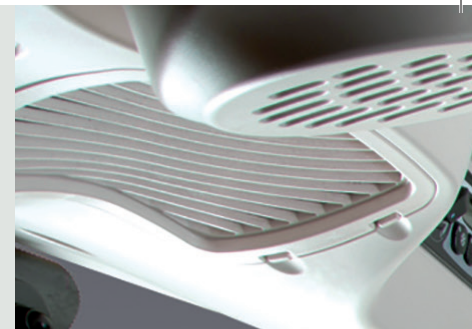

## LUXURY CABS: CHOOSE TO YOUR NEW FIELD OFFICE

The X7 series cab features a four-post frame with flat foot deck, large rear hinged doors that provide ease of access to the driving position, and a one-piece panoramic widescreen that gives all-round visibility. The deluxe upholstered swivel seat with dynamic air suspension system and fully automatic height adjustment features an optional climate control system and a multi-function right-hand armrest that houses the main tractor controls. Also integrated into the armrest is a 12" data screen manager (DSM) touch screen monitor that controls tractor performance and functions. The telescopic tilt-adjustable steering wheel is designed to tilt with the instrument panel.

The premium cab also includes several new features as standard equipment, including an inside rear view mirror, additional 12V sockets for portable devices, a bottle holder and a refined roof hatch frame.

The cab is pressurized to keep a clean, dust free environment and has a sound level of only 70 dBa. A highly efficient automatic climate control in Premium models maintains the desired cab temperature regardless of the outdoor weather conditions. To further increase operator comfort, an electronically-controlled hydraulic cab suspension system is available as an option.



X7 P6-Drive models available in premium configuration feature our premium cab with multi-function controls integrated into the right-hand armrest featuring the latest technology.



X7 P6-Drive models available in standard configuration feature our efficient cab with multi-function controls integrated into the right-hand console featuring mechanical valve controls.



Premium cab on all X7 VT-Drive models

## HIGHLIGHTS

- › 4-post cab design with spacious platform - Easy access
- › Deluxe air suspended swivel seat with optional ventilation - Increased operator comfort
- › Instrument panel tilting with steering wheel - Always visible
- › Available DSM color touchscreen monitor - Versatility
- › Automatic climate control available - increased operator comfort
- › Hide away instructor's seat - increased safety and ease of access
- › Ergonomic controls - versatile operation
- › Hydraulic cab suspension available - unmatched comfort
- › Pressurized cab for acoustic insulation - pleasant work environment
- › All transmission controls grouped into single control handle - Operator convenience



The driving position features a large and comfortable air-suspended driver's seat that can be optionally equipped with a heating and ventilation system. An instructor can also travel in comfort thanks to an innovative, upholstered seat, which neatly folds away to allow easier and safer access to the cab.



Modern and Intuitive, the digital front instrument panel keeps the operator constantly informed of the tractor's performance. The instrument panel is designed to tilt with the steering wheel so that it is always clearly visible.



The modern 12-inch DSM color touchscreen monitor is bright and provides easy and intuitive control of tractor functions. ISOBUS technology allows DSM to control ISO-compliant implements for convenient operation.



Heavy duty HVAC with twin blowers moves a high volume of air to keep the operator comfortable in any weather conditions. Automatic climate control in Premium models is conveniently built into a stylish roof console. An opening transparent roof hatch with sunshade provides extra visibility for loader operations.





Robust LED lighting packages available in the X7 series provide unmatched visibility throughout all hours of your work day. Simple operation within the cab allows for increased work capacity for the operator.



Simple operation and access to the controls for the heavy duty HVAC are integrated into the upper dash of the cab. Operators are able to control their temperature or opt for the automatic climate control available in premium cab configurations.



The premier radio system in X7 cabs allows for Bluetooth/MP3 radio connection. Operators can listen to entertainment via their MP3 player or Bluetooth compatible device, AUX connector, or even USB drive. This system also allows hand-free calling for increased convenience and safety.



On the left-hand console there is a chilled storage compartment. Temperature is maintained via an additional air conditioning vent located inside the console, which can also be turned off if needed.







# P6-DRIVE & VT-DRIVE TRANSMISSIONS: EFFICIENT AND VERSATILE



McCormick VT-Drive and P6-Drive transmissions have been designed, manufactured, and tested to ensure unmatched efficiency and versatility. McCormick transmissions are able to give a concrete answer to the specific work needs of every farm, open field, transport and livestock.



## VT-Drive Transmission: Simply Advanced Technology

The new X7 VT-Drive tractors offer smooth, reliable performance in any application. VT-Drive is a continuously variable transmission (CVT) that combines the efficiency and reliability of a mechanical gearbox with the infinite speed range of a hydrostatic drive system. The result is a tractor that can achieve any groundspeed, from zero to maximum transport, to match the needs of nearly any job around the farm.

The benefits of VT-Drive are found in its versatility. The engine and transmission work together to find the right engine RPM and travel speed for the job at hand: high RPM with low ground speed for draft or specialty applications, or high ground speed with low engine RPM for efficient transport applications.

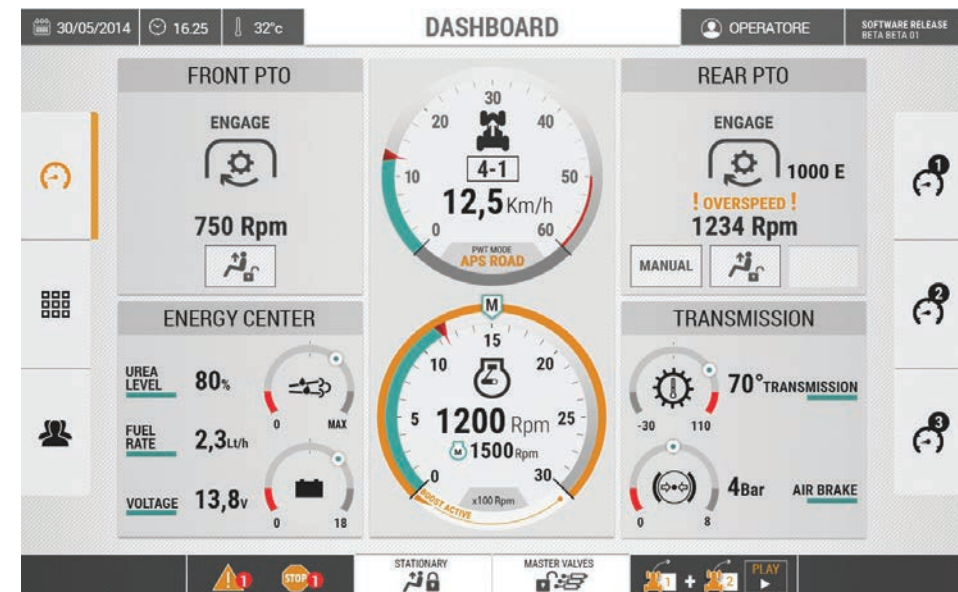



**VT-DRIVE, THREE VERSATILE OPERATING MODES:**

1. **Auto Mode:** the simplest way to drive the tractor. The operator simply uses the hand controls or foot pedal to accelerate, and the tractor does the rest - just like driving a car with an automatic transmission.
2. **PTO Mode:** The operator sets the engine RPM using the hand throttle and engages the PTO. The operator then uses the hand controls or foot pedal to accelerate. The tractor places priority on maintaining engine RPM (implement speed).
3. **Manual Mode:** The operator sets the engine RPM using the hand throttle. The operator then uses the hand controls or foot pedal to accelerate. The tractor places priority on maintaining ground speed.

**ELECTRO-HYDRAULIC POWER SHUTTLE**

The X7 tractors feature a reverse power shuttle with neutral position that allows the operator to automatically shift from forward to reverse, without use of the clutch pedal. The shuttle response is electronically modulated and adjustable by the operator if required for different tasks. Using a control knob in the covered portion of the armrest, the operator can adjust the transmission's response level, from ECO to POWER, to suit the needs of the job at hand.

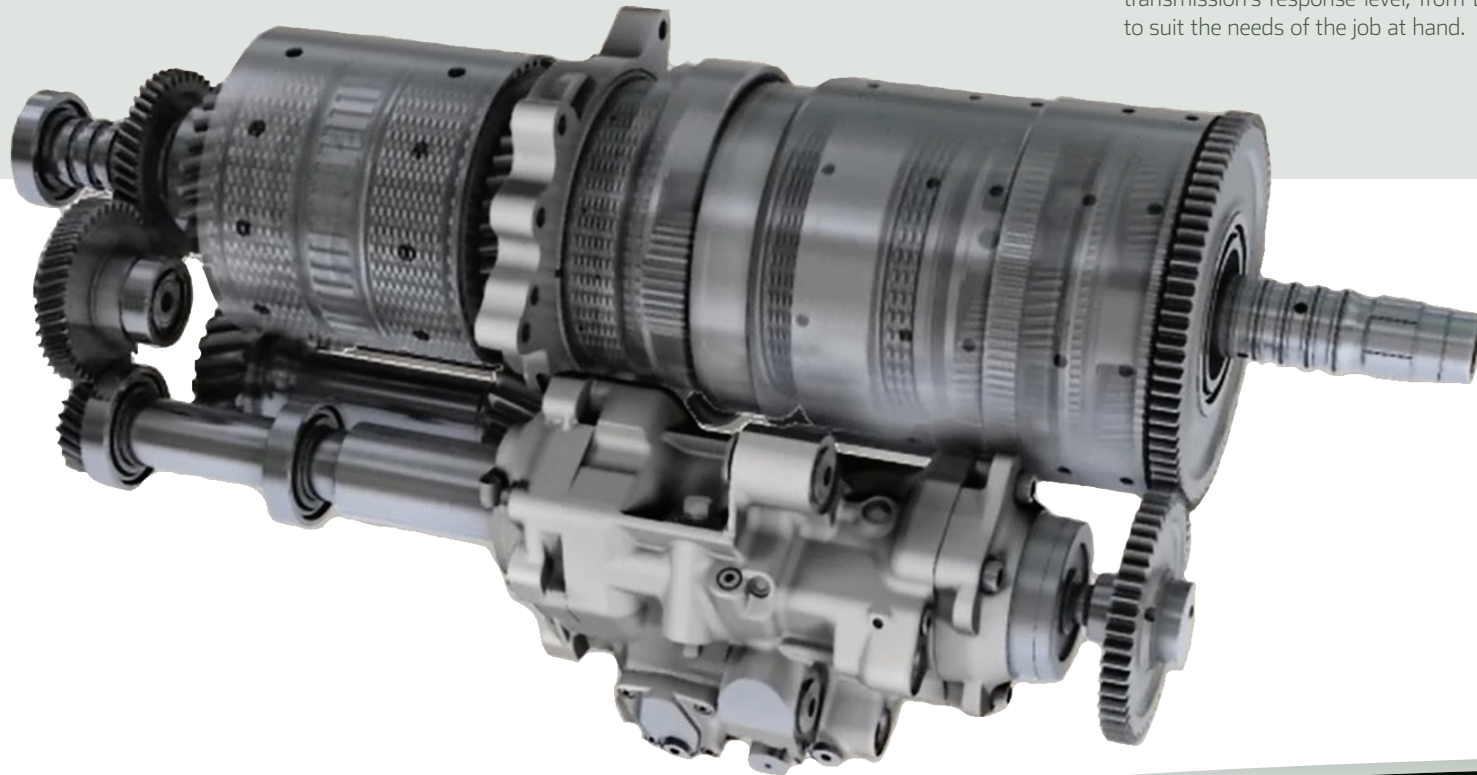

## P6-Drive Transmission: Maximum efficiency

The NEW P6-Drive Transmission features 30 speeds in 5 ranges with 6 powershift gears in each range. Incorporated is electronic range shifting and a separate, electro-hydraulic power shuttle. In addition, a creeper gearbox is standard, providing additional 24 forward and reverse speeds for a total of 54 speeds.

The P6-Drive transmission is designed to ensure the operator has the right speed for every application, and offers a top speed of up to 32mph (50kph) when properly equipped.

### ENGINE POWER MANAGEMENT WITH POWER PLUS

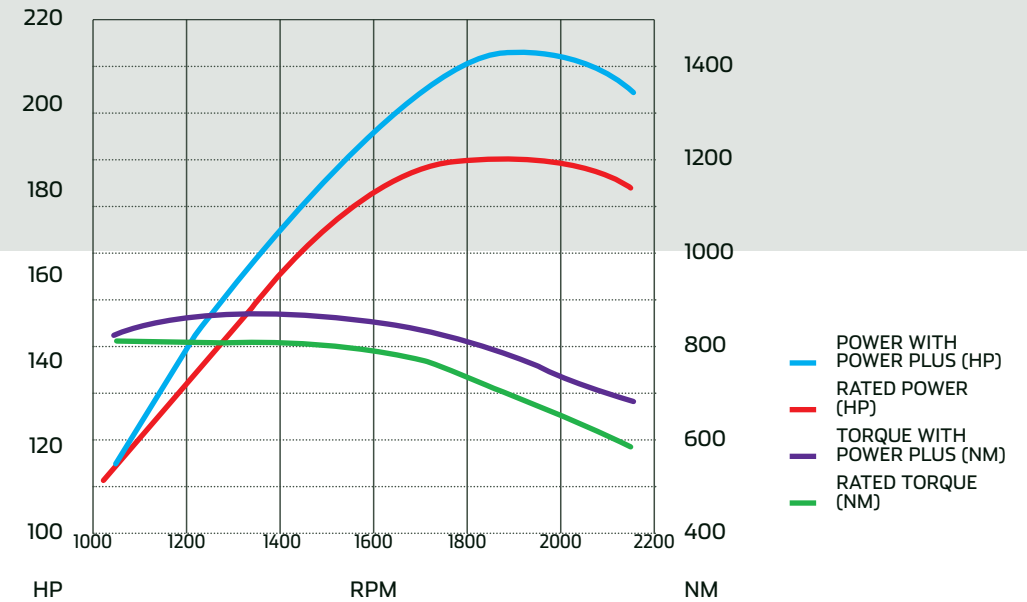

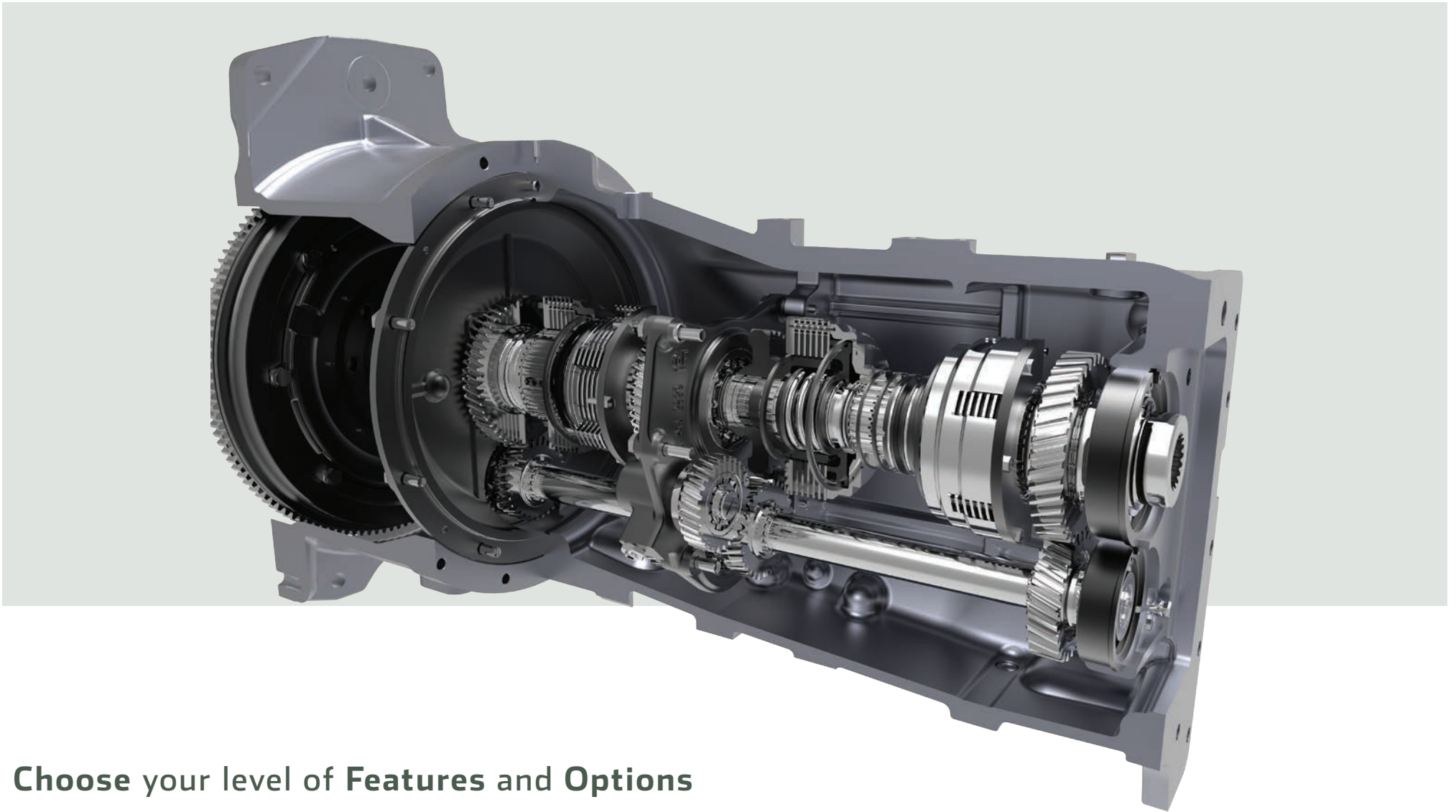

## Choose your level of Features and Options

### STANDARD CONFIGURATION

Designed for those who want simplicity, reliability, and versatility. Standard models include basic features and amenities that are paramount to simply getting the job done. Standard models incorporate most of the major tractor functions in the right hand console and include such features as P6-Drive transmission, closed center hydraulics with mechanical valve controls, simplified lighting package, manual HVAC, and air suspended seat, just to name a few.

### PREMIUM CONFIGURATION

The premium version of the X7 series means exactly as its name implies. Performance, technology, and comfort are all placed in the forefront to tackle any job around the farm. Major tractor controls are positioned in the right hand seat armrest for convenient, fingertip operation. Other premium features include choice of P6-Drive or VT-transmission, 32 mph (50kph) capability, higher flow closed center hydraulics with electronic valve controls, robust lighting package, automatic climate control, deluxe suspended seat, ISOBUS and auto-guidance capability, and so much more.







McCORMICK



## Traction, Maneuverability, and Comfort on all terrains

Outstanding traction is always guaranteed from the X7 Series, thanks to the heavy duty 4wd front axle and fully locking rear differentials at the front and rear. Both the 4wd and differential lock functions can be set to work automatically using either a built-in 'Auto' capability or the headland management system.

X7 tractors are extremely nimble and easy to drive. High capacity wet multi-disc rear axle brakes on each side of the differential are hydraulically boosted to ensure safe, controlled stopping power. The tractor may be optionally equipped with hydraulic and/or pneumatic trailer braking systems for total transport safety and road legislation. Connectors at the rear are easily accessible for trailer connection.

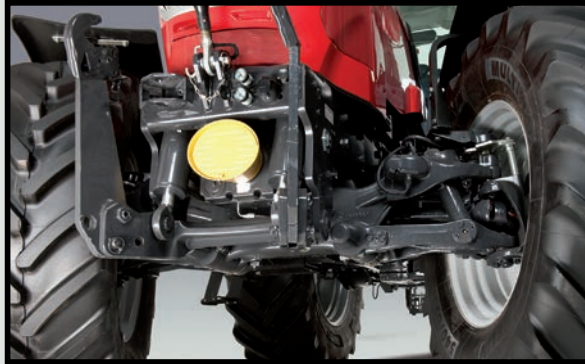

**CAB & INDEPENDENT FRONT AXLE SUSPENSION**

The X7 Premium models can be equipped with an electronically controlled independent front suspension system for extra comfort and increased performance. The suspended axle, along with the optional electro-hydraulic cab suspension, allows the X7 tractors to achieve superior levels of performance, ensuring maximum ride comfort and safety on all terrains.

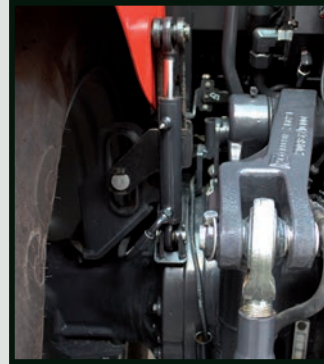

**AUTOMATIC 4WD AND DIFFERENTIAL LOCK ENGAGEMENT**

All X7 Series models are equipped with combined front and rear differential locks to reduce wheel slip and maximize traction.

The system is controlled electronically through an 'Auto' function, which automatically engages or disengages the differential lock and the four-wheel drive during headland turns. Engagement of the 4wd and differential lock can also be controlled automatically using the headland management function.

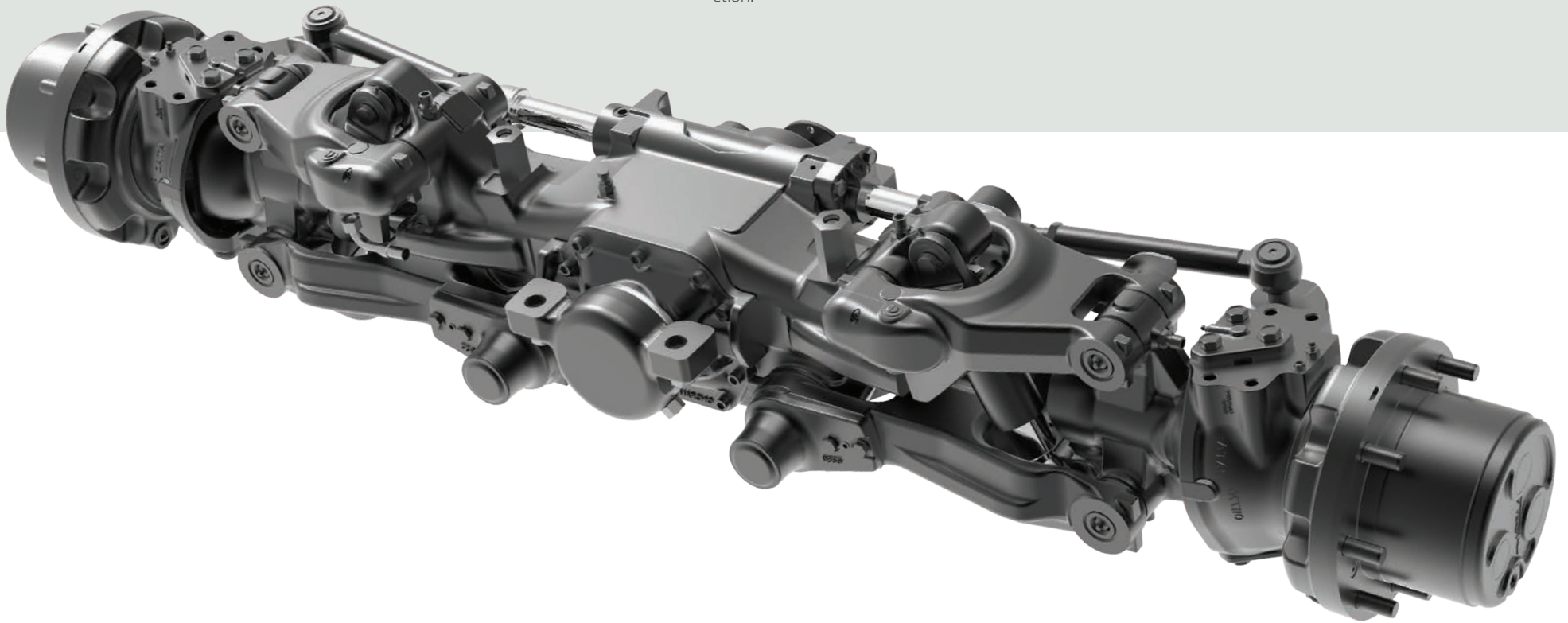

# BUILT TO WORK IN ALL APPLICATIONS AROUND YOUR FARM



The X7 Series boasts an electronically controlled rear hitch for precise implement control, a versatile 4 speed PTO for implement compatibility, constant PTO power with the Power Plus system for consistent implement speed, up to 5 dedicated rear remote valves for east implement connection, and rear fender controls for PTO, hitch, and remote valves for added convenience.

## BETAPOWER Performance for the Toughest Demands Versatile Rear-End for any Application

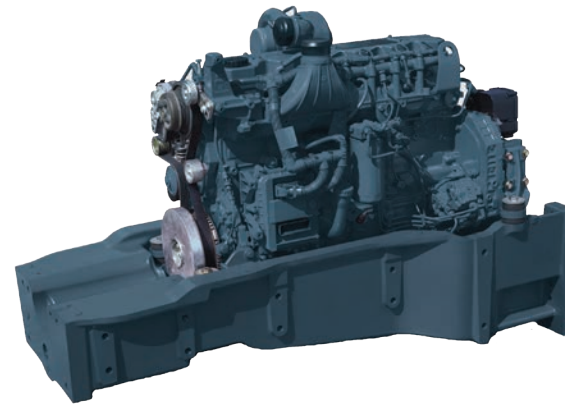

The 6-cylinder BETAPOWER engine features a thick cast steel front frame with ashock absorbing rubber mounts that support the engine in the rigid structure for added chassis strength, greater weight, and reduced noise and vibration levels within the cab.



### REAR PTO FUNCTIONS

The X7 range has been designed to operate in a variety of conditions with heavy, power demanding implements. The rear PTO includes four speeds (540/540E/1000/1000E RPM), and the driveline design ensures minimal power loss and maximum productivity. An electro-hydraulic wet multi-disc clutch ensures smooth and modulated engagement of the PTO, even under heavy loads. Models with PowerPlus will automatically increase the horsepower available when the PTO is engaged and under load.

External PTO and hitch controls are located on the rear fenders, making it easier to attach implements from the ground.

The Auto PTO feature will automatically disengage the PTO as the rear 3-point hitch raises, and engage the PTO as the hitch lowers. This reduces the potential for implement driveline damage and gives the operator precise control of a mounted implement during headland turns.



### FRONT HITCH AND PTO

A front hitch and PTO are available as an option on premium and VT-Drive Models. Combining front and rear implements provides greater tractor versatility and improves overall productivity. Control switches at the front allow the operator to raise and lower the hitch for easier implement connection.



**INTEGRATED GUIDANCE TECHNOLOGY:  
MORE PRECISION, MORE PERFORMANCE**

The X7 series Premium tractors have been designed to work with the latest technologies available to the agricultural community. Options for ISOBUS connectivity that allows the free flow of data between a tractor and connected implements, as well as an interactive 12-inch color touchscreen terminal for improved control over complete agricultural systems, help to keep the X7 on the cutting edge and deliver peak performance in nearly any application.

### **PRECISION STEERING MANAGEMENT**

The PSM option allows for control of an installed satellite guidance system. Specially designed for professional farmers, this technology can deliver a range of accuracies to fit different needs.

### **EAZYSTEER DYNAMIC STEERING SYSTEM**

Supplied in conjunction with the precision steering management option is the EazySteer quick steering system with dynamic management. This fly-by-wire technology lets the operator change the hydraulic steering ratio with the press of a button, allowing the tractor to make a U-turn with only a single complete revolution of the steering wheel.



Configuring a tractor “guidance ready” means that all hardware to support satellite guidance is installed at the factory for simple, clean connection of any ISO-compliant guidance system.



## MCCORMICK PARTS AND SERVICE: YOUR AFTER SALES RESOURCE

Even in spare parts and after-sales services, the McCormick brand is always a symbol of quality and reliability. Original McCormick parts, manufactured according to the highest quality standards, ensure the best performance and safety of each tractor because they are developed by the same team that designs and builds our tractors. Parts are delivered to our dealers quickly and efficiently, with each piece being

guaranteed for 12 months. Service is carried out by specialized personnel equipped with the most advanced diagnostic technology. Our competent service team is knowledgeable, reliable and oriented to problem solving.

Choosing McCormick means choosing excellence.





## FRONT END LOADERS



### High Performance Front Loaders

Each X7 tractor can be equipped with a front loader to improve overall versatility. All McCormick loaders are built by Alo, a global leader in the design and manufacture of front loaders. Customers can choose between self leveling and non-self leveling designs to match individual needs. Each loader can be quickly removed and installed without tools to improve the tractor's versatility. Alo's popular "Euro-type" quick attachment system for loader tools lets the operator quickly and easily change between loader buckets and tools.

Loader Model		L61	L68	L78
Loader Type		Non-Self Leveling	Self Leveling	Self Leveling
Max. Lift Height to Pivot Point	in (mm)	167 (4250)	167 (4250)	181 (4600)
Lift Capacity to Max. Height 31.5" (800mm) Fwd of Pivot Pin	lb (kg)	4,190 (1900)	5,450 (2470)	5,490 (2490)
Breakout Force from Ground Level 31.5" (800 mm) Fwd of Pivot Pin	lb (kg)	9,130 (4140)	10,010 (4540)	10,140 (4600)
Max. Lift Height Under Level Bucket	in (mm)	155 (3950)	155 (3950)	169 (4300)
Compatible Tractor Model		X7.650 / X7.660 / X7.670 / X7.690		

**SPECIFICATIONS**

<b>Tractor Model</b>		<b>X7.650</b>	<b>X7.660</b>	<b>X7.670</b>	<b>X7.690</b>
Configurations Available		Standard Premium	Standard Premium	Standard Premium VT- Drive	Standard Premium
<b>Performance</b>					
Rated Engine HP @ 2200 RPM	HP (kW)	146 (107)	160 (118)	175 (128)	199 (146)
Max. Engine HP @ 1600 RPM	HP (kW)	151 (111)	165 (122)	180 (133)	205 (151)
Max. Engine HP @ 2000 RPM <i>with power plus</i>	HP (kW)	165 (122)	180 (133)	192 (141)	225 (165)
Max. PTO HP @ 2000 RPM	HP (kW)	130 (95)	142 (104)	153 (112)	177 (130)
Max. Engine Torque @ 1400 RPM	lb ft (Nm)	466 (632)	512 (694)	599 (758)	627 (850)
Torque Rise		41%	41%	41%	37%
<b>Engine</b>					
Engine Type	BETAPOWER diesel engine; Tier 4 using advanced Selective Catalytic Reduction (SCR) technology				
Engine Size	6.7 Liter, 6-cylinder				
Fuel / DEF Capacity	gal (liter)	85 (320) / 12 (46)			
<b>Drive Train</b>					
Transmission Type	Standard & Premium: 'P6-Drive' 54 x 27 power shift and power shuttle; standard 8:1 creeper; 32 mph (50 kph) capable VT-Drive: 'Continuously Variable Transmission' CVT with seamless acceleration				
Gears and Ranges	P6-Drive: 5 Ranges, 6 powershift speeds VT-Drive: 4 CVT Ranges				
Rear Axle	Internal planetary final drives; wet disc brakes; flange with bar axle adaptors				
Differential Lock	Front and rear fully locking differentials; electronic control; hydraulic engagement				
4wd Front Axle	Push button engagement, center locking differential; outboard planetary final drives; 4-wheel braking; available suspension on Premium & VT Models				
<b>Hydraulics, 3-point Hitch, PTO</b>					
Implement Hydraulic System Type/Max. Flow	gpm (lpm)	Closed Center PFC; variable displacement pump 32.5 (123), steering pump 11.6 (44) Option on Premium models only: higher flow system, variable displacement pump 44 (160)			
Rear Remote Valves	Standard Model: 3 valves Premium & VT-Drive: 3 standard, 6 optional				
Rear 3-point Hitch Type	Category 3 / 3N (narrow); electronic control				
Rear 3-point Lift Capacity @ Hitch	lb (kg)	14,000 (6300) on Standard models; 20,500 (9300) on Premium models			
Rear PTO	540 / 540E / 1000 / 1000E standard; electro-hydraulic engagement; rear fender controls				
<b>Operator's Area</b>					
Cab	Large 4-post structure; 2 doors; flat foot deck; high capacity HVAC; roofline window; available suspension on Premium & VT Models				
Seat and Front Dash	Deluxe air suspended seat; tilt and telescopic steering wheel; hide-away instructor's seat; front dash with user interface				
Wheelbase	in (mm)	108 (2750)		111 (2820)	
Height Over Cab with Standard Wheels	in (mm)	115 (2920)		120 (3055)	
Overall Length with Front Weights	in (mm)	207 (5260)			
Base Weight without Ballast	lb (kg)	15,013 (6810)		P6-Drive: 15,013 (6810) VT-Drive: 16,245 (7360)	15,454 (7010)

\* Manufacturer's calculated estimate. \*\* With PowerPlus feature (boost). Boosted power is available only when certain operating conditions are met.



McCormick North America  
[www.McCormickNA.com](http://www.McCormickNA.com)

updated: 01.22.2019

